

Zum Einbetonieren mit Schalungrahmen H=250
For concreting with formwork frame H=250

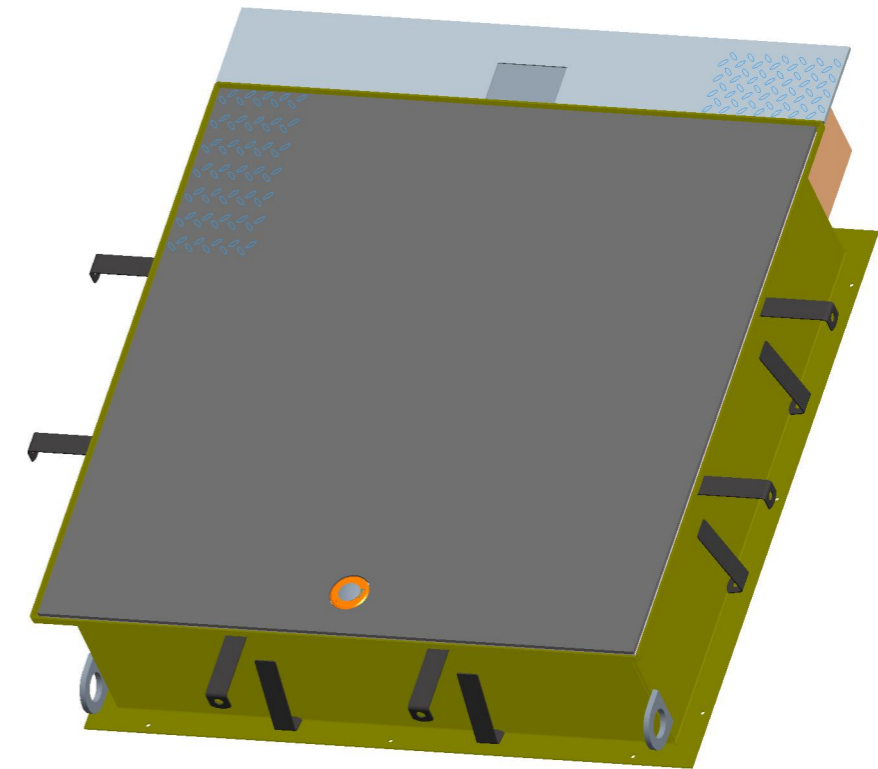
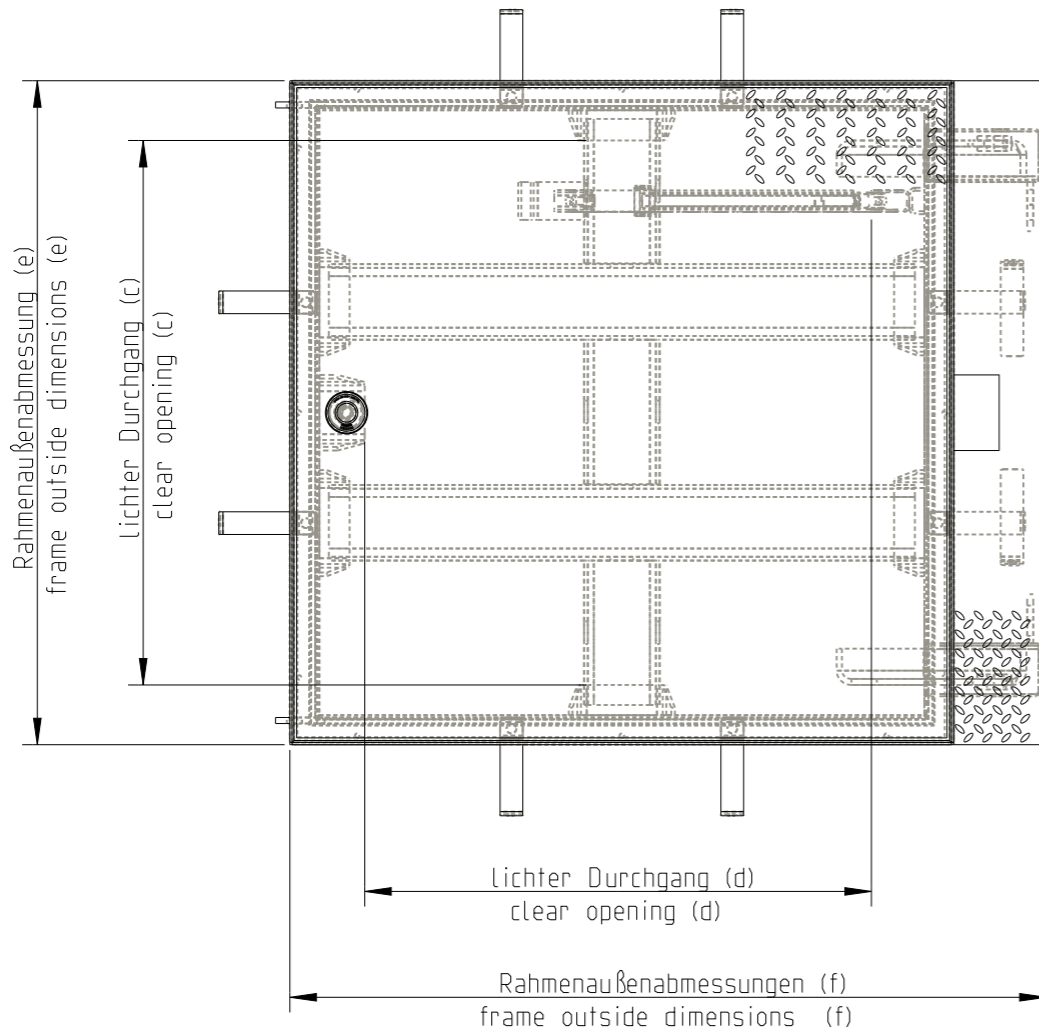
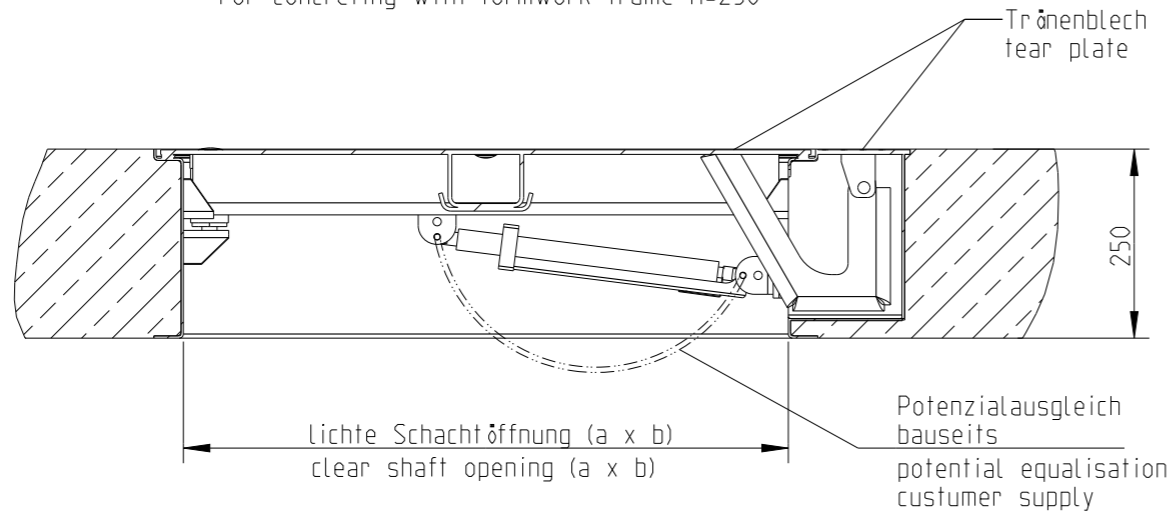

Diese Zeichnung ist geistiges Eigentum der Fa. HUBER SE und damit urheberrechtlich geschützt. Zuwiderhandlungen verpflichten zum Schadensersatz.
This is a copyrighted drawing which is the intellectual property of HUBER SE. Any contravening offender will be held liable for payment of damages.

HUBER
TECHNOLOGY

WASTE WATER Solutions
D-92334 Berching / Tel.: +49-8462-201-0

Technische Änderungen vorbehalten / Subject to change

ISO 2768-mK

				Datum/Date	Name
				Bear./Rev. 16.03.2016	hb
g	draw. revised	15.07.20	hrl	Gepr./Appr. 30.08.2021	ged

Maßblatt

sheet of dimensions

SD7

Revision	Änderung Modification	Tag Date	Name	Norm.	

Projekt project		Production drawing	Massstab scale	Blatt sheet
-----------------	--	--------------------	----------------	-------------

1:10

50947805 1/2